

FIGURE 1
MINIMUM SIGHT
LINES AT
INTERSECTIONS

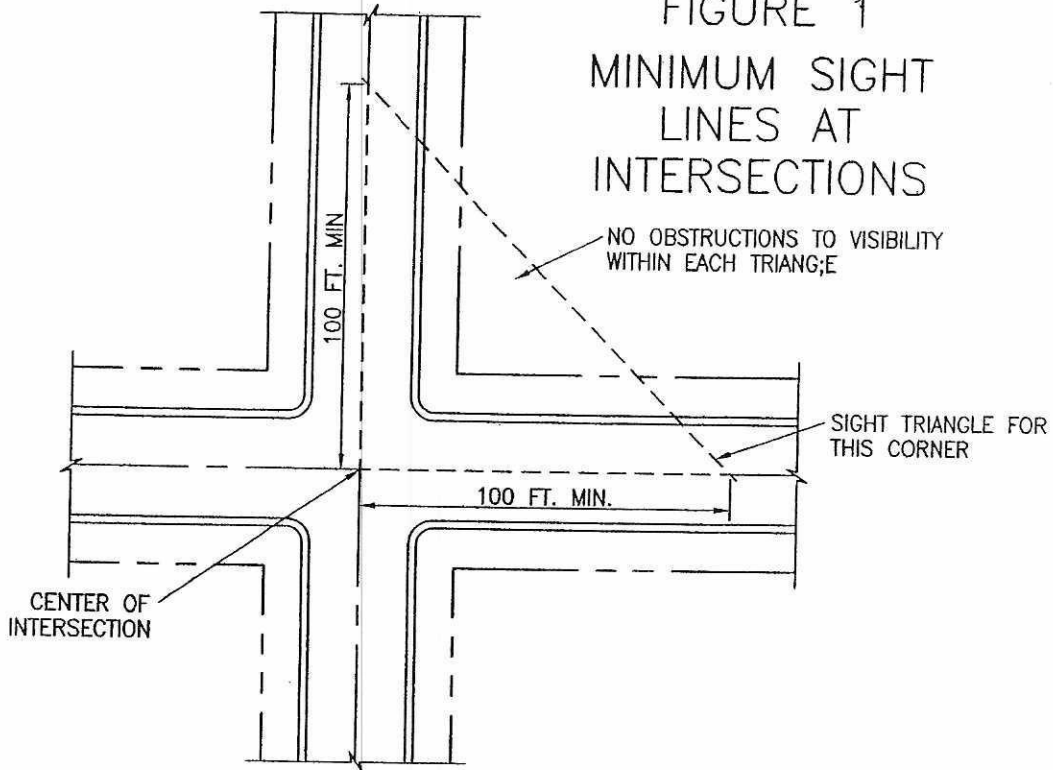

FIGURE 2
MINIMUM
REVERSE
CURVES

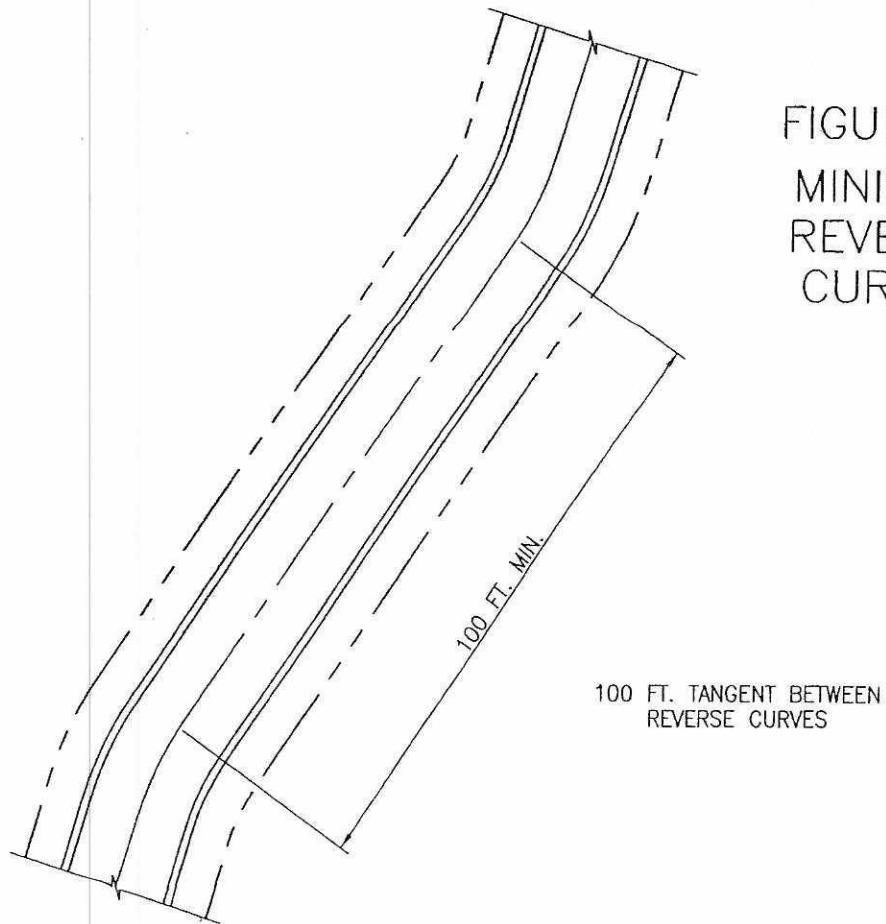
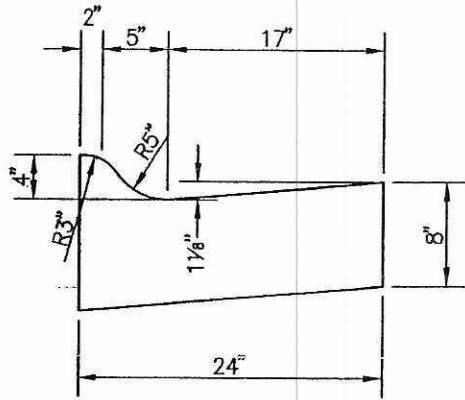
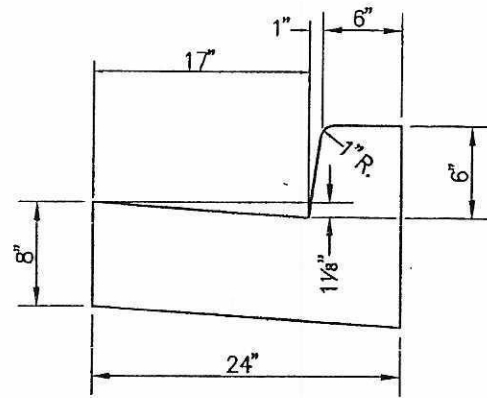

FIGURE 3
TYPICAL CURB AND GUTTER



ROLLED CURB



BARRIER CURB

FIGURE 4
TYPICAL CUL-DE-SAC

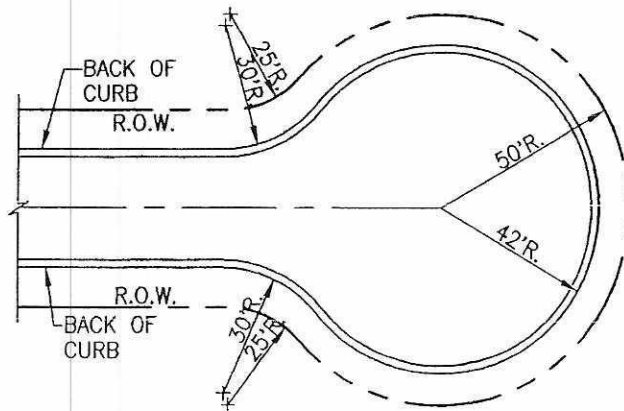
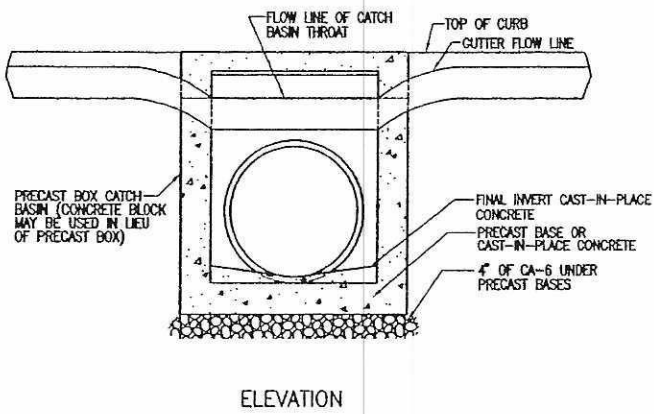
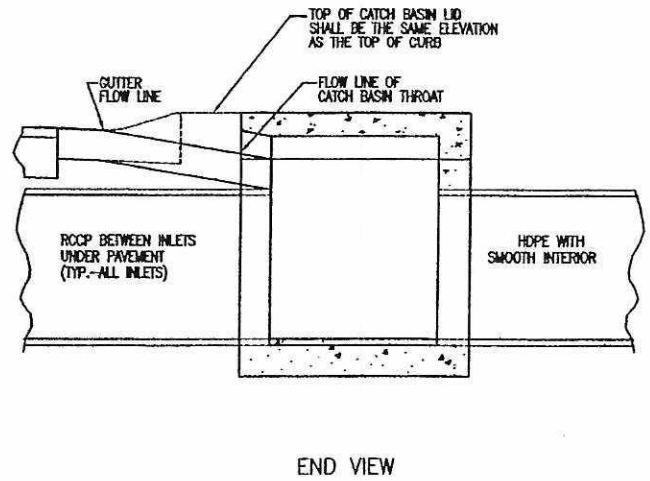
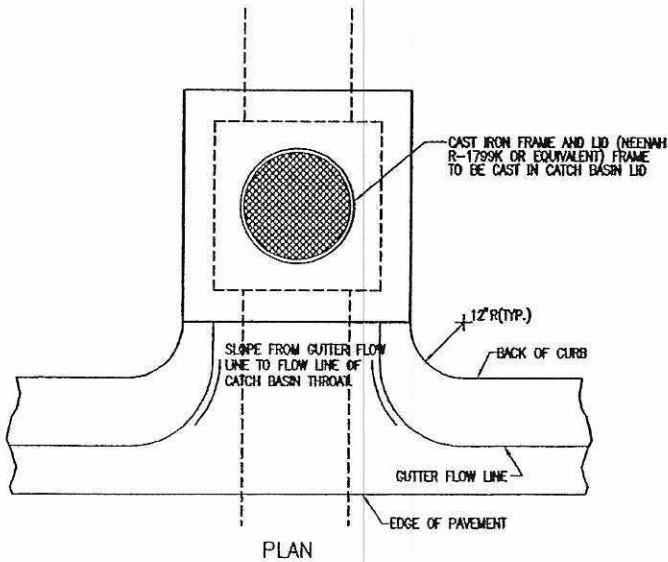
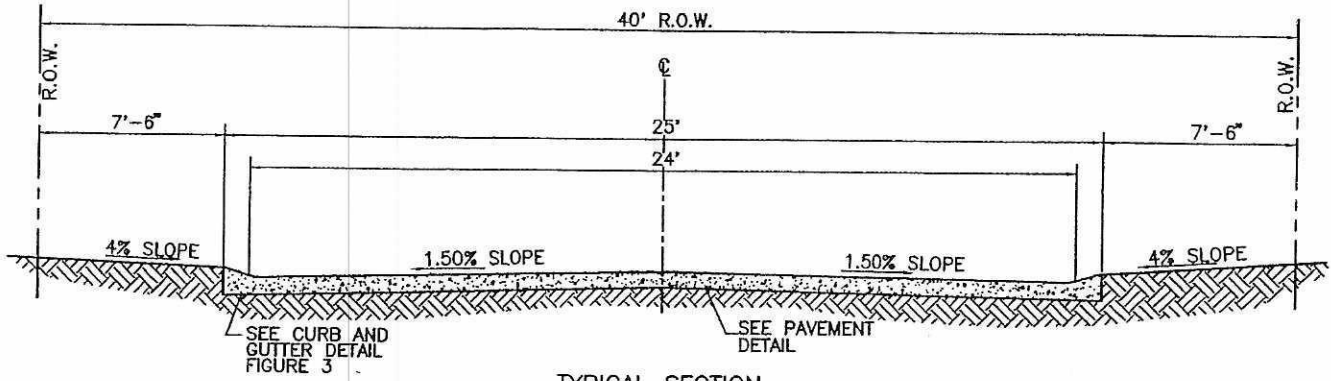
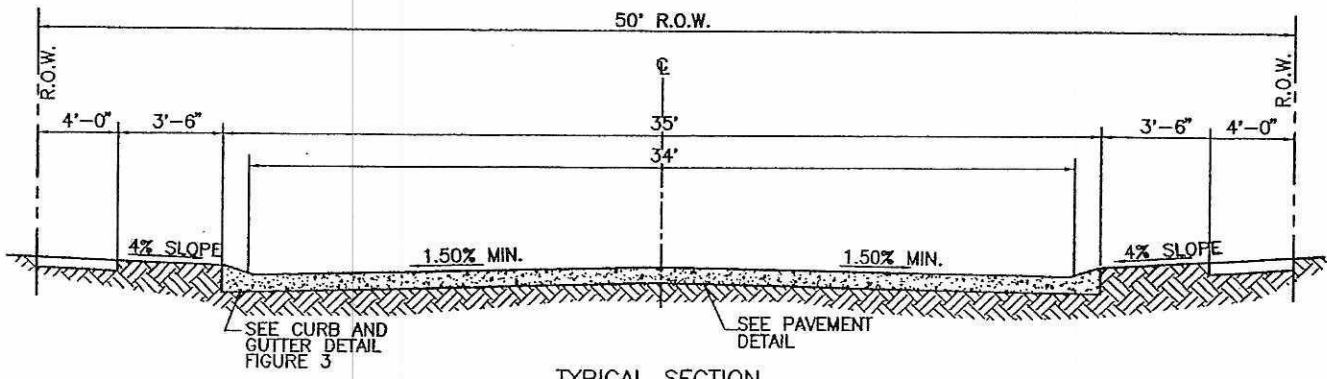

FIGURE 5
TYPICAL CURB INLET





TYPICAL SECTION
MARGINAL ACCESS STREET



TYPICAL SECTION
LOCAL STREET

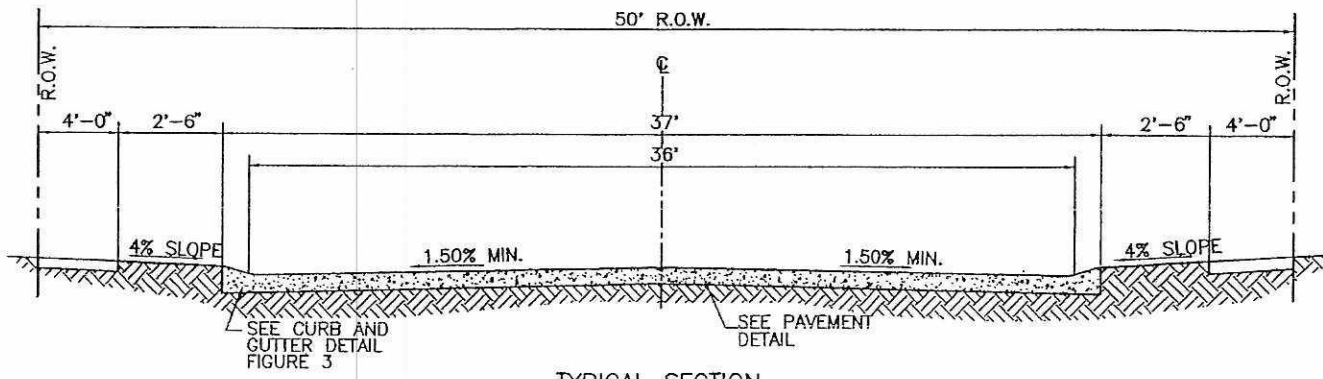

TYPICAL SECTION
RESIDENTIAL COLLECTOR STREET

FIGURE 6

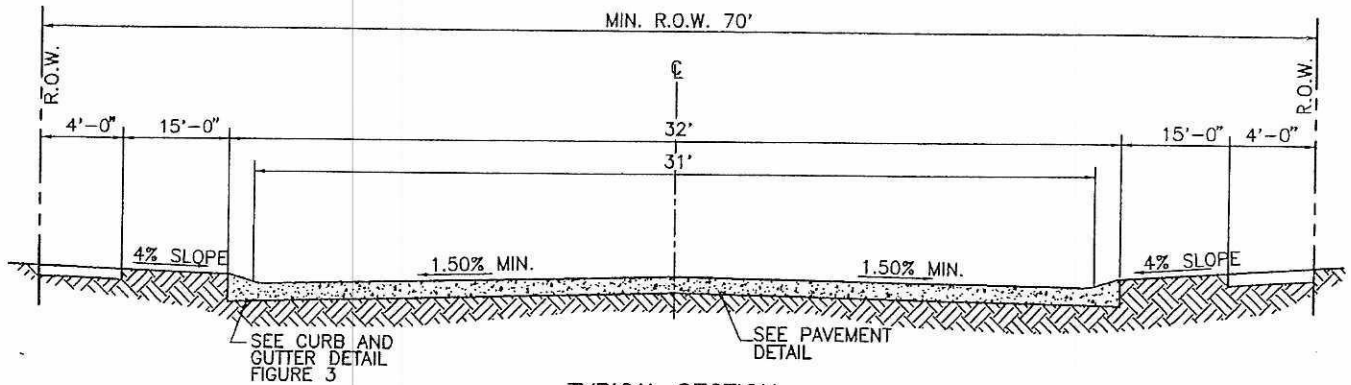

TYPICAL SECTION
ARTERIAL STREET

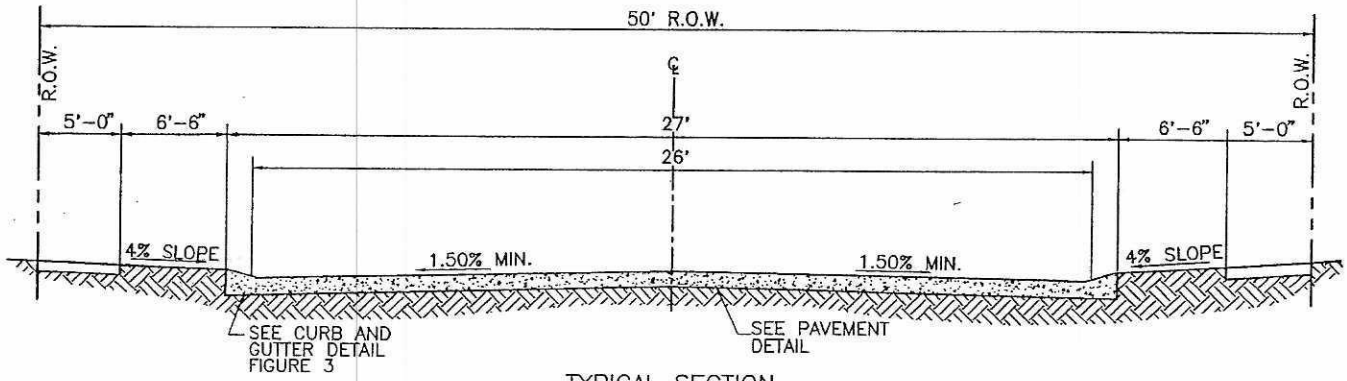

TYPICAL SECTION
COMMERCIAL AND INDUSTRIAL LOCAL STREET

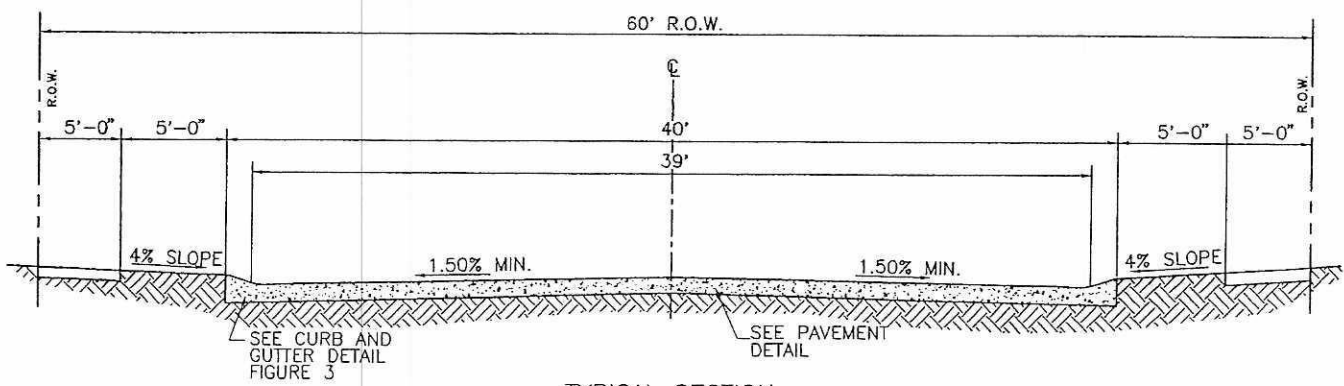

TYPICAL SECTION
COMMERCIAL AND INDUSTRIAL COLLECTOR STREET

FIGURE 7

[This page was left blank intentionally.]